

### BABY CHANGING STATION, HORIZONTAL – PLASTIC, SURFACE MOUNTED, MATTE BLACK

Baby Safe Solutions

MasterFormat Section 10 28 13

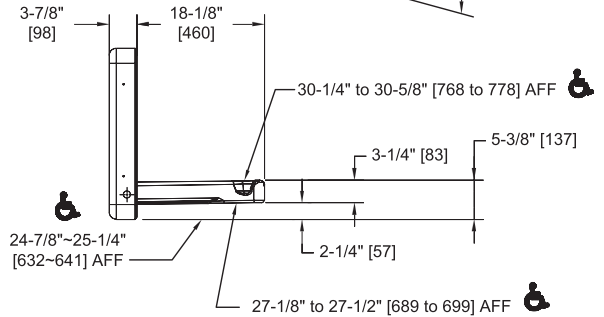
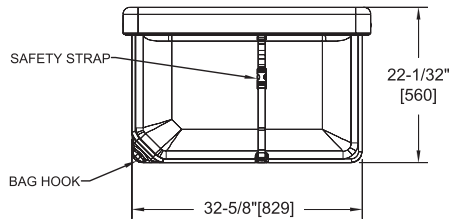
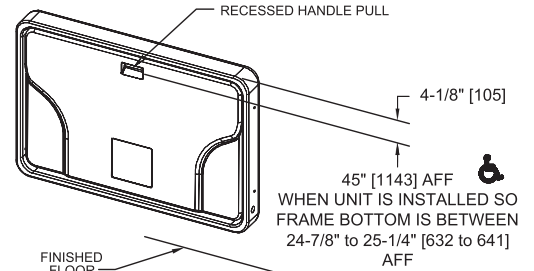
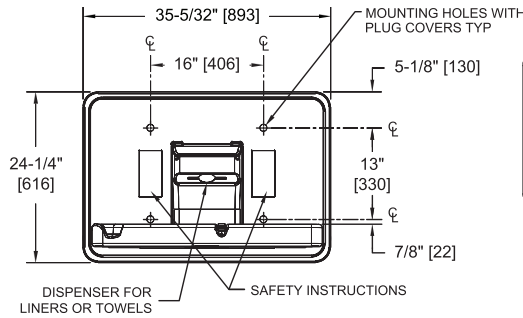

**NOTE:**  
ALL DIM'S INCH [MM]  
CSA = CONCEALED SCREW AXIS



### SUSTAINABILITY

MR 4.1 (1) MR 6 (1) EQ 4.2 (1)  
MR 4.2 (1) EQ 4.1 (1) EQ 4.4 (1)

### PRODUCT OVERVIEW

Fabricated of FDA-approved fungus and bacteria-resistant plastic. Its vinyl-coated, adjustable safety strap assures child protection. Unit platform is shaped to keep a child restrained from rolling out of the bed. Unit is easily opened and closed by user with one hand. Unit complies with with 2010 ADA Accessibility Standards, ASTM F-2285 & F-2388, G-21, G-22, ANSI Z535, ANSI 117.1, EN 12221-1, and EN 12221-2 (Including A1:2013). Tested during development to sustain 250 lbs (113 kg) static load with minimal deflection. Bed liner/towel dispenser presents liners or towels for user hygiene and convenience. Dispenser lid is provided for sanitary protection and ease of loading of wipes or liners. Safety strap is easily adjustable by user for baby size and Sure-Lock latch securely resists opening until released by opposing finger pressure by adult caretaker/parent. Surface Mounted.

### KEY FEATURES & SPECIFICATIONS

- ADA, ASTM F-2285 & F-2388 (100 lbs [45.4 kg] static load test required), G-21, G-22, ANSI Z535, ANSI 117.1, EN 12221-1, and EN12221-2 (Including A1:2013) compliant. Damped gas spring aids one handed operation using less than 5lbs force (22.2N) - no tight grasping, pinching or twisting of the wrist.
- Includes one integral bag hook and bed-liner dispenser (convertible to a multi-fold towel dispenser).
- Changing Surface is fabricated of FDA-approved fungus and bacteria-resistant HDPE.
- Designed to support an infant up to 3 1/2 years old and a weight up to 50 lbs (23 kg).
- The bed is designed to cradle a child's body. An adjustable two-part, vinyl-coated safety strap with a Sure-Lock latch aids in safety.
- Matte Black finish.

**OPERATION & MAINTENANCE**

Unit platform is shaped to keep a child restrained from rolling out of the bed. Unit is easily opened and closed by user with one hand in any location and handle cavity is provided on door face for preferred use. Unit is operable with less than 5 lbs (22.2N) while not requiring any tight grasping, pinching or twisting of the wrist. Bed liner/ towel dispenser presents liners or towels for user hygiene and convenience. Dispenser lid is provided for sanitary protection and ease of loading of wipes or liners. Safety strap is easily adjustable by user for baby size and Sure-Lock latch securely resists opening until released by opposing finger pressure by adult caretaker/parent. Liners/ towels are easily replenished by service personnel as required.

**TECHNICAL INFORMATION / PRODUCT PROPERTIES**

Property	Value
Dimensions	Closed: 893 x 616 x 98 mm Open: 893 x 616 x 560 mm
Construction	High-Density Polyethylene (HDPE) FDA-approved fungus and bacteria-resistant plastic bed
Mounting	Surface Mounted
Capacity	Supports an infant up to 3 ½ years old and a weight up to 23 kg. Tested during development to sustain 113 kg static load with minimal deflection.

**INSTALLATION**

Installation instructions along with operation and maintenance manual are provided with each unit. Surface mount unit using hardware supplied through recessed mounting holes. Hardware kit supplied has fasteners suitable for metal or wood stud walls in dry locations and general hollow wall construction where adequate substrate strength is obtained. Fasteners and anchors for masonry walls are not provided. Wall reinforcement must be suitable to sustain transfer of maximum unit loading. Mounting hole plug covers are supplied to conceal fasteners after installation. Installation instructions along with operation and maintenance manual are provided with each unit. Unit is surface mounted using hardware supplied through recessed mounting holes. Hardware kit supplied has fasteners suitable for metal or wood stud walls in dry locations and general hollow wall construction where adequate substrate strength is obtained. Fasteners and anchors for masonry walls are not provided. Wall reinforcement must be suitable to sustain transfer of maximum unit loading. Mounting hole plug covers are supplied to conceal fasteners after installation.

1. Locate wall studs at 16" [406] OC for fastening the station. If two (2) wall studs cannot be used, use two (2) screws into ONE stud and drill pilot holes and install toggle fasteners securely in the wall at non-stud location.
2. Attach unit to wall studs with four (4) 1/4" x 3" long Phillips pan head self-threading screws through flat washers.
3. Where wall studs are not available attach with four (4) 1/4" - 20 x 3" pan head bolts with flat washers into toggles or expansion nuts.

For compliance with 2010 ADA Accessibility Standards install unit so that top edge of changing table is 30-1/4" [768] Above Finished Floor (AFF). See installations instructions packed with unit.

**WARRANTY**

Five (5) Years from date of invoice.

Distributed by OZWASHROOM Tel: 1300652715 Email: orders@ozwashroom.com.au Web: ozwashroom.com.au